

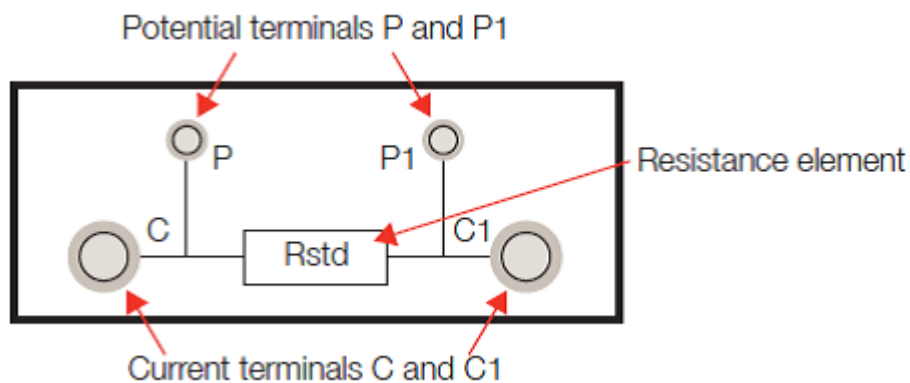

How do we measure low resistance?

There are a number of methods that can be utilised but by far the best method of measurement for low resistance values below 100Ω is the 4 Wire technique (also known as the Kelvin Method). All Seaward low resistance ohmmeters use this method to ensure accuracy of readings. The principle of this method negates any additional resistances due to test lead resistance. These measurements are made using 4 separate wires. 2 wires carry the current, known as the source or current leads and pass current through the sample under test. The other 2 wires known as the sense or potential leads, are used to sense the voltage drop across sample. Whilst some small current will flow in the sense leads, it is negligible and can be ignored. The volt drop across the ohmmeter's sense terminals is therefore virtually the same as the volt drop across test sample. This method of measurement will produce accurate and consistent results when measuring resistances below 100Ω

For optimal accuracy of measurement, the current wires must always be placed outside the potential leads, although the exact placement is not critical. The potential wires must be connected exactly at the points you want to measure between. The measured value will be between the potential points. For example if we wanted to measure the resistance of a sample of cable, lets say 1m, it would be normal practice to place the potential leads exactly 1m apart, with the current leads placed outside of these.



Whilst the above method gives the best measurement results it is often not the most practical, We live in a non perfect world and sometimes small compromises have to be made, for example it may not always be possible to place the leads apart due to the available connection point. For this reason Seaward can offer a number of practical measurement solutions, including Kelvin Clips and Cable clamps to aid connections in any application.

If you require more help, please contact us at <https://www.seaward.com/cms/enquiry/>.